

Metamark DS-400

Premium Heavyweight Roller Banner Stand

Specifications

Finished Graphic Panel Size

2300 (h) X 800 (w)mm
(includes 200mm bleed)

Visual Graphic Size

2100 (h) X 800 (w)mm (10mm of graphic hidden by top gripping hanger.)

Recommended Media

Metamark MD-RU200 / MD-RU330

Maximum Finished Graphic Panel Thickness

250 micron

Assembled Size

2175 (h) X 820 (w) X 180 (d)mm

Weight

4.5kg

Components List

DS-400 unit
3 part telescopic pole
Graphic hanger with self adhesive strip
Carry bag

Warranty:

2 years from date of purchase.
This covers product failure due to manufacturing defects only.

METAMARK
The Materials Company

Assembly Instructions

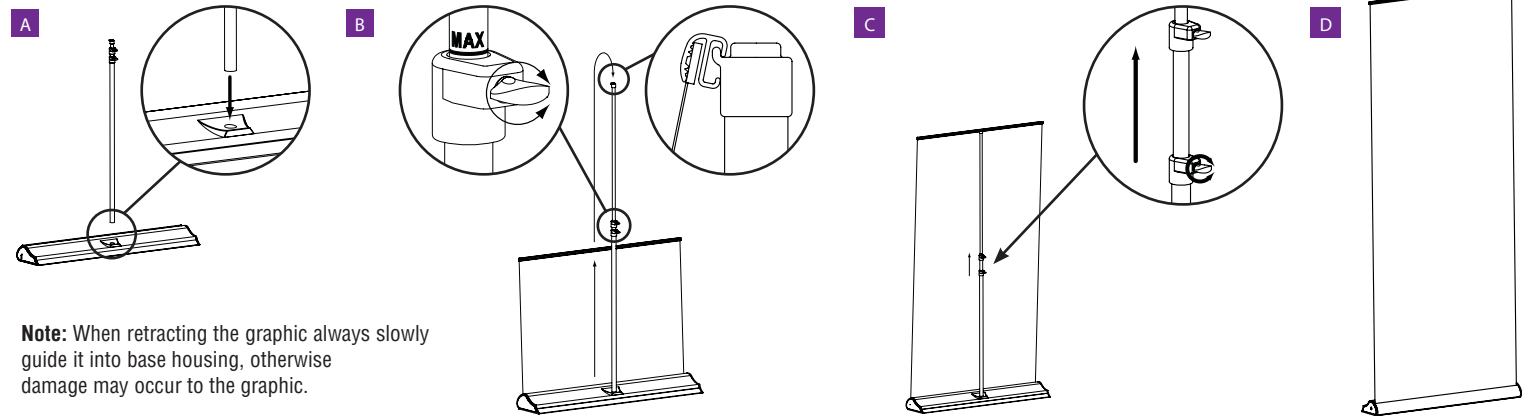

Note: When retracting the graphic always slowly guide it into base housing, otherwise damage may occur to the graphic.

Graphic Attachment

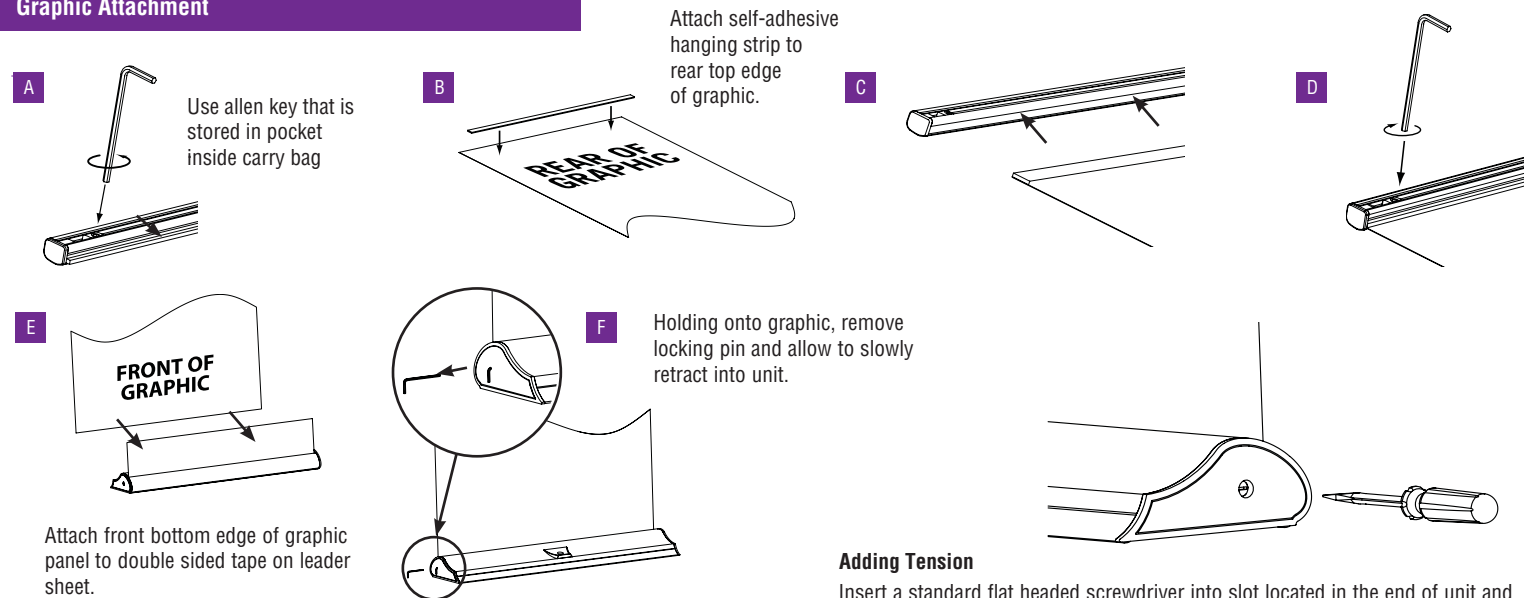

Adding Tension

Insert a standard flat headed screwdriver into slot located in the end of unit and turn clockwise to add extra graphic tension.

Removing Tension

To un-tension graphic panel place a flat headed screwdriver into the slot and push to disengage ratchet. Hold in and turn anti-clockwise until tension in spring is released. To remove graphic panel carefully peel it off leader sheet. The graphic hanger can also be removed.